

HOSE, VALVE AND EXTINGUISHER SECURITY CABINETS

1900 and 1900SS Cabinets are constructed to meet maximum security requirements in areas where protection is needed.

STANDARD EQUIPMENT for 1900 SERIES:

- * 12 gauge solid panel door
- * 14 gauge steel tub and trim
- * White powder coat
- * HD continuous hinge
- * HD masonry anchors welded to frame
- * Mortise Prep Lock

STANDARD EQUIPMENT for 1900SS SERIES:

- * Stainless steel door
- * Stainless Steel # 4 finish
- * HD continuous hinge

OPTIONS:

- * Recessed flush cup
- * Red powder coat
- * Lettering
- * FR Options (Fire rated door with glass)
- * Duo panel, with clear 1/2" Lexan glazing

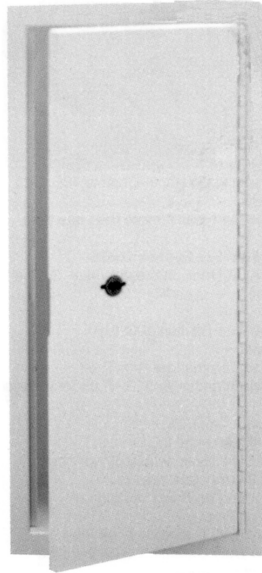

1900 Series

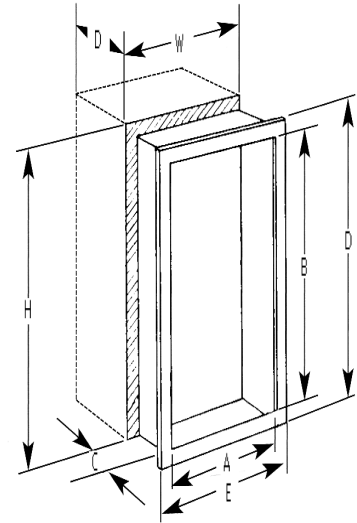

Tub for 1900 Series

FIG. NO.	STAINLESS STEEL	TRIM STYLE	TUB ID			FRAME OD		NON-RATED			FX OPTION			LOCATION		CAPACITY	WEIGHT LBS.
			A	B	C	E	F	W	H	D	W	H	D	J	K		
1900	1900SS	Recessed	10 1/2	24	6 1/2	12 1/2	26	11 1/2	25	7	12 1/2	26 1/2	7 1/2	N/A	N/A	Croker 4002,4005	25
1902		Semi-Rec.2 12"	10 1/2	24	6 1/2	12 1/2	26	11 1/2	25	4 1/2	12 1/2	26 1/2	5	N/A	N/A	4006, 4010, 4302, 4305	26
1908	1908SS	Surf Mtd.	13	26 1/2	8	13	26 1/2							N/A	N/A	4306, 4310 and 4405 CO2	26
1910	1910SS	Recessed	12	27	8 1/2	14	29	13	28	9	14	29 1/2	9 1/2	N/A	N/A	All Croker BC And ABC	33
1912		Semi-Rec.2 12"	12	27	8 1/2	14	29	13	28	6 1/2	14	29 1/2	7	N/A	N/A	Ext. 4202 2 1/2 gallon WP	34
1918	1918SS	Surf Mtd.	14 1/2	29 1/2	10	14 1/2	29 1/2							N/A	N/A	4405 and 4410 CO2 Ext.	34
1920	1920SS	Recessed	18	18	8 1/2	20	20	19	19	9	20	20 1/2	9 1/2	5	5	2 1/2 Fire Dept. Valves	32
1922		Semi-Rec.2 12"	18	18	8 1/2	20	20	19	19	6 1/2	20	20 1/2	7	4 1/4	4 1/4		33
1928	1928SS	Surf Mtd.	20 1/2	20 1/2	10	20 1/2	20 1/2							N/A	N/A		33
1930	1930SS	Recessed	32 3/4	34 3/4	8	34 3/4	36 3/4	33 3/4	35 3/4	8 1/2	34 3/4	37 1/4	9	4	4	2 1/2 X 1 1/2 Rack Units 2 1/2 Valves and Extinguishers	88
1932		Semi-Rec.2 12"	32 3/4	34 3/4	8	34 3/4	36 3/4	33 3/4	35 3/4	6	34 3/4	37 1/4	6 1/2	4	4		95
1938	1938SS	Surf Mtd.	36 3/4	38 3/4	8	36 3/4	38 3/4							N/A	N/A		104

Add 1" to Frame Dimensions for Cabinets with FR Option

LOCK AND HINGE OPTIONS

MORTISE PREP OPTIONS:

Includes mortise cylinder deadbolt, prep or a mortise cylinder cam lock prep. Mortise cylinder of 1 1/18 diameter by 5/16" length is provided and installed by others.

DETENTION LOCK, PREP OR INSTALLED:

Heavy duty detention deadlock provided and installed by others.

DDL can be factory installed

DDL-1 has slam latch

DDL-2 cast steel case with bronze cylinder stainless steel deadbolt



Detention Locks

SECURITY FASTENERS:

Tamper proof screws which fasten through the doors to nuts welded behind the door stops. Special tool required to gain access.

HIGH SECURITY HINGE:

Heavy duty surface hinges at 2 3/4" X 3" X 1/4" available with solid leaves for welded installation.